



Air cooled chillers

POWERCIAT LX R407C

Screw compressors
 CIAT *direct expansion*
 shell and tubes evaporator
 Hydraulic pack versions
 “Plug and Cool”
 H.P.S. equipment (High Power System)



Cooling capacity : 230 to 1100 kW



Cooling



Hydraulic module



Heat recovery



USE

The new generation of **POWERCIAT LX water chillers** offers an optimal solution to all the refrigeration applications encountered in the air conditioning or industrial process.

This range is designed with the latest generation of components : accessible hermetic twin screw compressors, modulating capacity control, communicating control and management by Xtra Connect microprocessor, components optimized for the ecological refrigerant HFC 407C.

This range is also proposed with an integrated hydraulic module : **POWERCIAT LXH**. This one includes all the elements required for a right operation of the unit : buffer tank, expansion vessel, single or twin pump, air vent , pressure relief valves , shut off valves , manometers...

A range with compact hydraulic equipment (without buffer tank) is also available : **POWERCIAT LXC**.

Units in accordance with EN 60-204 - EN 378-2 regulations and directives :

- Machines (98/37 CEE) modified
- CEM (89/336 CEE) modified 92/31 CEE - 93/68 CEE
- Low voltage (73/23 CEE) modified 92/31 CEE - 93/68 CEE
- DESP 97/23 CEE

→ **LX - LXH - LXC**

- group 2 sizes 1200Z (HPS) to 1850Z (HPS)
- group 3 sizes 2150Z (HPS) to 2800Z (HPS)
- group 4 sizes 3050Z HPS to 4200Z HPS

RANGE

POWERCIAT LX - LXH - LXC

2 compressors, 2 refrigerant circuits :

12 models : 1200Z, 1200Z HPS, 1500Z, 1500Z HPS, 1850Z, 1850Z HPS, 2150Z, 2150Z HPS, 2500Z, 2500Z HPS, 2800Z, 2800Z HPS

3 compressors, 3 refrigerant circuits

4 models : 3050Z HPS, 3400Z HPS, 3750Z HPS, 4200Z HPS

■ CONFIGURATION

- a - **HIGH PERFORMANCE** version
Ventilation 905 rpm
- b - **LOW NOISE** version (LN)
Ventilation 715 rpm + compressors sound insulation
- c - **XTRA LOW NOISE** version (XLN)
Specific mounting for 715 rpm fans + compressors sound insulation



DESCRIPTION

POWERCIAT LX serie

■ Compressors

- Accessible hermetic twin screw type
- Optimized profile of rotors ensuring a high efficiency
- Electrical motor incorporated with **part-winding starting**
- Motor integral electronic protection
- Control of the phases balance and rotation direction
- Integrated overpressure valve
- Discharge temperature control
- Lubrication under controlled pressure
- 3-stage integrated oil separator
- Crankcase heater
- Suction filter
- Discharge valve
- Slide for modulating capacity control
- Compressors fitted on anti-vibration mounts

■ Evaporator

- Direct expansion shell and tube type
- High performance copper tubes bundle
- Steel shell
- Corrosion resistant baffles
- Thermal insulation by cellular foam with UV resistant polyurethane film

■ Air cooled condenser

- Copper tubes coils, aluminium fins
- Direct drive propeller fans
- Rotation speed : **905 or 715 rpm**
- 3 phase electrical motors, IP 54
- Standardized protection grilles

■ HPS (High Power system) on models LX/LXH/LXC...HPS



■ The HPS system allows to increase cooling capacity, improves the performance coefficients (EER) of your installation, particularly in part load, and ensures therefore an optimal operation of POWERCIAT during all the year.

■ Refrigerant accessories

- Filter dryers with rechargeable cartridges
- Liquid sight glasses
- Solenoid valves on liquid refrigerant lines
- Thermostatic expansion valves

■ Safety and regulation devices

- HP/LP pressure sensors
- Low and high pressure safety valves
- Chilled water control sensor (inlet and outlet)
- External temperature sensor

- Evaporator antifreeze sensor
- Compressors discharge sensor
- Evaporator water flow switch

■ Electrical panel

- IP 44
- Electrical supply 400 V - 3 ph. - 50 Hz + earth (-5% / +4%)
- Wires numbering and electrical components referencing
- Main fuse disconnect safety switch with external handle
- Transformer for control circuit
- Compressors motors contactors
- Fans motors contactors
- Fuse-protected compressor motors
- Fans motors protection
- Main electrical ground
- Phase monitor (reversal, loss, over and under voltage)

■ Electronic control with microprocessor Xtra connect

ensuring the following main functions :

- 2 remote switchable set points
- Chilled water temperature control
- Possibility of water temperature variation as a function of the outside temperature (water law)
- Low temperature energy storage control
- Condensing pressure control
- Compressors discharge temperature control
- Compressors anti-short cycle control
- Control and optimisation of operating parameters
- Counting and balancing of compressors, pumps operating times
- Automaticity control
- LCD display panel, 2 lines of 20 characters allowing :
 - parametering of the unit
 - direct reading of all information : settings, water inlet/outlet temperatures, outside temperature, HP/LP pressures, unit operating status...
 - Faults control with memorization of the last 9 faults and operating logbook when those faults occur
 - Weekly management of the unit
 - Unit general fault display on terminals
 - Automaticity control on terminals
 - RS 485 output for bus connection with centralized Building Management System.

■ Capacity control

- Modulating capacity control :
 - from 25 to 100 % (sizes 1200Z (HPS) to 2800Z (HPS))
 - from 17 to 100 % (sizes 3050Z HPS to 4200Z HPS)

■ Frame and casing

- Frame in RAL 7035 and 7024 painted metal sheet
- Casing in RAL 7035 and 7024 lacquered metal sheet



Air cooled chillers

POWERCAT LXH serie

The design of **POWERCAT LXH units** is identical to the one of POWERCAT LX

These units integrate the **complete hydraulic** equipment for standard installation :

- 1 insulated buffer tank , capacity : 950 litres
- 1 monocellular centrifugal hydraulic pump (**single** or **twin** pump)
- 1 expansion vessel (80 litres)
- 1 automatic air vent
- 1 manual air vent
- 1 safety valve calibrated at 4 bars
- A drain hole
- 2 shut off valves for the pump
- 1 set of manometers
- Contactors, protection devices and control for pumps inside the unit electrical panel.

POWERCAT LXC serie

The design of **POWERCAT LXC units** is identical to the one of POWERCAT LX

These units integrate the **a compact hydraulic equipment**

- 1 monocellular centrifugal hydraulic pump (single or twin pump)
- 1 expansion vessel (80 litres)
- 1 automatic air vent
- 1 manual air vent
- 1 safety valve calibrated at 4 bars
- A drain hole
- 2 shut off valves for the pump
- 1 set of manometers
- Contactors, protection devices and control for pumps inside the unit electrical panel.

OPTIONS

- **LOW NOISE (LN)** version : ABS phonic insulation casing with sound proof material + 715 rpm fans
- **XTRA LOW NOISE (XLN)** version : ABS sound insulation casing with soundproof material + specific mounting for 715 rpm fans
- Compressors suction valves
- Evaporator antifreeze protection (LX serie)
- Evaporator antifreeze protection + piping + hydraulic equipment (LXH - LXC series)
- Condenser coil treatment :
 - polyurethane coated fins
 - polual blygold coating
- Anti-vibration mounts
- Evaporator flexible connections
- Remote control box
- Voltage free relay card
- Heat recovery with brazed plates desuperheaters (1 per refrigerant circuit)
- Low temperature glycol water
- Electronic expansion valve
- Soft start
- Management of several units MULTICONNECT
- Optimised high pressure
- Fans speed variator
- LonWorks gateway
- Container handling equipment
- Shackles



POWERCAT LX serie



VERSION WITH HYDRAULIC EQUIPMENT

LXH - LXC series

Hydraulic equipment LXH serie

The "ALL INTEGRATED" solution

The PLUG and COOL solution offered by POWERCAT LXH - LXC

The hydraulic equipment integrates all the components necessary for the correct operation of the installation :

- 950 litres insulated buffer tank (LXH only)
- 80 litres expansion vessel
- Large choice of single or twin pumps for high head pressure (1)
- Manometers with shut off valves
- Pressure relief valves (calibrated at 4 bars)
- Drain circuit
- Manual and automatic air vent
- Control of the assembly
- Antifreeze protection (optional)

The hydraulic equipment, whose components have been selected in an optimal way, mounted and tested in factory, makes the installation of units easy and economical.

The preparation/commissioning times and the space required on site are therefore perfectly optimised.

(1) Our pumps are designed for operation on a closed water loop (low NPSH). For other applications, consult us (open water circuit, important intake height, etc).

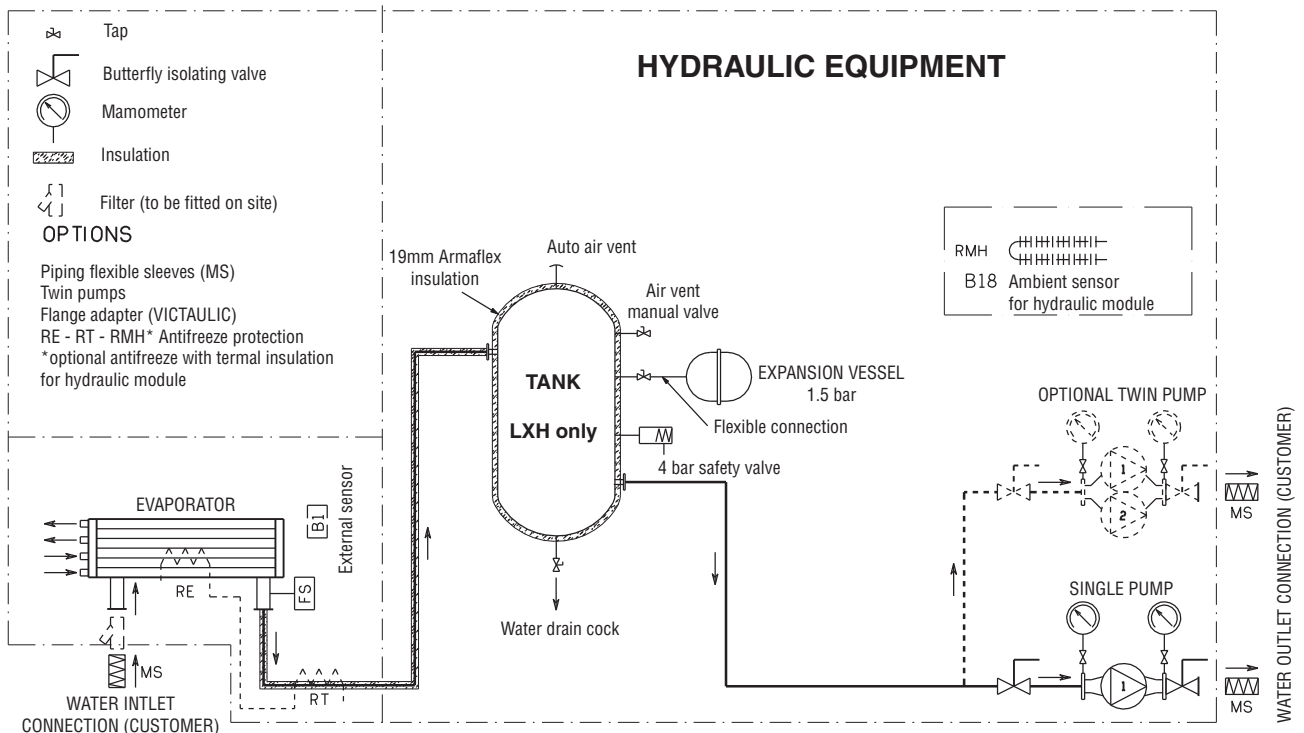



TECHNICAL CHARACTERISTICS

POWERCAT LX - LXH - LXC			1200Z	1200Z HPS	1500Z	1500Z HPS	1850Z	1850Z HPS	2150Z	2150Z HPS
High performance version	Cooling capacity (1)	kW	236	261	305	338	362	409	429	486
	Absorbed power (2)	kW	101	110	129	140	156	172	184	202
	EER/ESEER		2.31/2.92	2.37/2.92	2.35/2.94	2.41/2.96	2.32/2.91	2.38/2.98	2.32/2.89	2.41/2.94
Low noise and xtra low noise versions	Cooling capacity (1)	kW	230	258	300	335	354	402	420	478
	Absorbed power (2)	kW	101	109	128	138	155	173	182	209
	EER/ESEER		2.28/2.97	2.37/2.95	2.34/3.05	2.43/3.06	2.27/2.96	2.32/2.96	2.3/2.98	2.29/3.02
Compressor	Type		Accessible hermetic twin screw							
	Number		2							
	Rotation speed	rpm	2900							
	R407C refrigerant charge (kg)	circ.1	23	24	40	45	55	56	55	56
		circ.2	23	24	25	26	25	26	45	46
	Capacity control		Modulating from 25 to 100% (50 to 100% on each compressor)							
	Type of oil for R407C		BITZER BSE 170							
	Oil charge for compressor	litres	2 x 9		15 + 9		22 + 9		22 + 15	
Evaporator	Type		Direct expansion shell and tubes							
	Number		1							
	Water capacity	litres	56,5				68		85	
	Hydraulic connections		VICTAULIC type							
	Maximum pressure on water side	bar	10							
Mini / maxi water flow	m³/h	30 / 82				40 / 100		60 / 135		
Air cooled condenser	Fans		Direct drive propeller type - 800 mm diameter							
	Number of fans		4				6		8	
	Rotation speed	rpm					HIGH PERFORMANCE version 905 rpm			
	Air flow	m³/h	88 000		136 000		132 000		180 000	
	Motor unit power	kW	2,6							
	Rotation speed	rpm					LOW NOISE - XTRA LOW NOISE versions 715 rpm			
	Air flow	m³/h	72 400		112 200		108 600		148 400	
High performance version	Lw / Lp (3)	dB(A)	96/64				98/66		100/67	
	Low noise version (LN)	Lw / Lp (3)	90/58				92/60		95/62	
	Xtra low noise version (XLN)	Lw / Lp (3)	85/53				87/55		88/55	

POWERCAT LX - LXH - LXC			2500Z	2500Z HPS	2800Z	2800Z HPS	3050Z HPS	3400Z HPS	3750Z HPS	4200Z HPS	
High performance version	Cooling capacity (1)	kW	522	594	605	690	740	820	903	1076	
	Absorbed power (2)	kW	216	238	244	268	287	320	362	413	
	EER/ESEER		2.42/3	2.5/2.95	2.47/3.05	2.57/3.06	2.57/3.26	2.55/3.05	2.49/3.07	2.4/3.07	
Low noise and xtra low noise version	Cooling capacity (1)	kW	509	582	595	685	725	803	881	1045	
	Absorbed power (2)	kW	216	235	240	262	303	331	364	437	
	EER/ESEER		2.36/3.01	2.48/2.95	2.48/3.16	2.61/3.15	2.39/3.21	2.42/3.1	2.42/3.21	2.35/3.13	
Compressor	Type		Accessible hermetic twin screw								
	Number		2							3	
	Rotation speed	rpm	2900								
	R407C refrigerant charge (kg)	circ.1	55	60	62	63	62	60	60	86	
		circ.1	55	60	62	63	50	60	60	92	
		circ.1	-	-	-	-	50	45	60	92	
	Capacity control		Modulating from 25 to 100% (50 to 100% on each compressor)				Modulating from 17 to 100% (50 to 100% on each compressor)				
	Type of oil for R407C		BITZER BSE 170								
Oil charge for compressor	litres	2 x 22				22 + 2 x 15		2 x 22 + 15		3 x 22	
Evaporator	Type		Direct expansion shell and tubes								
	Number		1								
	Water capacity	litres	122						219		440
	Hydraulic connections		VICTAULIC type								
	Maximum pressure on water side	bar	10								
Mini / maxi water flow	m³/h	60 / 135				80 / 180		80 / 216			
Air cooled condenser	Fans		Direct drive propeller type - 800 mm diameter								
	Number of fans		8				12		15		
	Rotation speed	rpm					HIGH PERFORMANCE version 905 rpm				
	Air flow	m³/h	176 000		276 000		272 000		268 000		
	Motor unit power	kW	2,6								
	Rotation speed	rpm					LOW NOISE - XTRA LOW NOISE versions 715 rpm				
	Air flow	m³/h	144 800		228 000		224 400		220 800		
High performance version	Lw / Lp (3)	dB(A)	101/68				101/68		102/69		
	Low noise version (LN)	Lw / Lp (3)	96/63				97/64		98/65		
	Xtra low noise version (XLN)	Lw / Lp (3)	89/56				91/58		91/58		

(1) Cooling capacity for 12°C / 7°C evaporator chilled water and 35°C condenser air inlet.

(2) Compressors + fans absorbed power

(3) Lw : Global sound power level - Lp : Global sound pressure level at 10 metres, in free field, following ISO 3744 regulation



Air cooled chillers

POWERCIAT LX R407C

ELECTRICAL CHARACTERISTICS

POWERCIAT LX - LXH - LXC		1200Z	1200Z HPS	1500Z	1500Z HPS	1850Z	1850Z HPS	2150Z	2150Z HPS							
COMPRESSORS (1)																
Maximum nominal current	A	216 (2 x 108)		270 (162+108)		324 (216+108)		378 (216+162)								
Part winding starting current (3)	A	377		531		720		774								
Starting current with SOFT START option (3)	A	283		377		506		560								
FAN MOTORS (1)																
HIGH PERFORMANCE version 905 rpm																
Maximum nominal current	A	24		36				48								
LOW NOISE - XTRA LOW NOISE versions 715 rpm																
Maximum nominal current	A	12,8		19,2				25,6								
LX ANTIFREEZE PROTECTION (OPTION) (2)																
Evaporator heating element power	W	180				240										
Maximum nominal current	A	0,80				1,05										
LXC ANTIFREEZE PROTECTION (OPTION) (2)																
Evaporator + hydraulic pipe + expansion vessel heating element power	W	420		480				540								
Maximum nominal current	A	1.83		2.1				2.35								
LXH ANTIFREEZE PROTECTION (OPTION)																
Evaporator heating element power + piping	W	300		420				480								
Maximum nominal current	A	1,3 (2)		1.83 (2)				2.1								
Hydraulic module heating element power	W			1500												
Maximum nominal current	A			2,3 (1)												
CONTROL AUXILIARY CIRCUIT (2)																
Maximum nominal current	A			4												
Transformer power	VA			1600												
POWERCIAT LX - LXH - LXC		2500Z	2500Z HPS	2800Z	2800Z HPS	3050Z HPS	3400Z HPS	3570Z HPS	4200Z HPS							
COMPRESSORS (1)																
Maximum nominal current	A	432 (2 x 216)		492 (2 x 246)		540 (216 + 2 x 162)	594 (2 x 216 + 162)	648 (3 x 216)	738 (3 x 246)							
Part winding starting current (3)	A	828		911		936	990	1044	1157							
Starting current with SOFT START option (3)	A	614		647		722	776	830	924							
FAN MOTORS (1)																
HIGH PERFORMANCE version 905 rpm																
Maximum nominal current	A	48		72				90								
LOW NOISE - XTRA LOW NOISE versions 715 rpm																
Maximum nominal current	A	25,6		38,4				48								
LX ANTIFREEZE PROTECTION (OPTION) (2)																
Evaporator heating element power	W			320												
Maximum nominal current	A			1,40												
LXC ANTIFREEZE PROTECTION (OPTION) (2)																
Evaporator + hydraulic pipe + expansion vessel heating element power	W			560												
Maximum nominal current	A			2.5												
LXH ANTIFREEZE PROTECTION (OPTION)																
Evaporator heating element power + piping	W	560				500										
Maximum nominal current	A	2,5 (2)				2,20 (2)										
Hydraulic module heating element power	W			1500												
Maximum nominal current	A			2.3 (1)												
CONTROL AUXILIARY CIRCUIT (2)																
Maximum nominal current	A			4												
Transformer power	VA	1600				2000										
SINGLE PUMPS (LXH - LXC ONLY) (1)																
Number		102	103	104	105	106	107	108	109	110	111	112	113	114	115	116
Power	kW	3	4	4	5,5	5,5	7,5	7,5	11	11	11	15	15	18,5	22	30
Maximum nominal current	A	6,3	8,0	8,0	10,3	10,3	13,8	13,8	20,0	20,0	20,0	26,5	26,5	32,5	39	53
TWIN PUMPS (LXH - LXC ONLY) (1)																
Number		202	203	204	205	206	207	208	209	210	211	212	213	214	215	216
Power	kW	3	4	4	5,5	5,5	7,5	7,5	11	11	11	15	15	18,5	22	30
Maximum nominal current	A	6,3	8,0	8,0	10,3	10,3	13,8	13,8	20,0	20,0	20,0	26,5	26,5	32,5	39	53

(1) Current for 400V / 3PH / 50HZ voltage

(2) Current for 230V / 1PH / 50HZ voltage

(3) Starting current of the biggest compressor + maximum current of others

compressors in full load

Nominal current for cables selection = add the maximum nominal currents indicated in the above tables



Air cooled chillers

POWERCIAT LX R407C

PERFORMANCES

POWERCIAT LX-LXH-LXC HIGH PERFORMANCE version

LX LXH LXC	Evaporator water outlet temperature °C	CONDENSER AIR INLET TEMPERATURE °C												
		26		29		32		35		38		41		
		Pf kW	Pa kW	Pf kW	Pa kW	Pf kW	Pa kW	Pf kW	Pa kW	Pf kW	Pa kW	Pf kW	Pa kW	
3050 Z 	Glycol water	-8	448.7	205.1	429.7	215.5	421.4	228.0	402.0	241.0	383.0	255.3		
		-6	478.5	208.3	466.5	219.7	450.0	231.7	437.8	245.0	424.8	260.0		
		-4	513.4	211.9	502.3	223.8	491.8	237.0	471.0	249.7	457.1	264.4		
		-2	575.9	218.3	559.2	230.4	547.0	243.8	526.2	257.0	513.8	270.2	501.4	288.0
		0	619.8	223.2	601.4	235.2	585.0	248.6	572.3	262.5	549.9	276.4	531.5	294.1
		2	658.2	227.1	642.7	240.1	626.7	254.0	606.9	267.9	587.9	281.8	574.2	301.2
	Pure water	5	753.9	237.9	733.2	251.2	718.3	266.3	695.1	280.8	680.1	297.9	643.8	317.3
		6	771.6	240.1	758.2	253.4	739.2	269.0	719.1	284.5	699.5	301.1	678.5	321.3
		7	796.7	243.1	778.9	256.4	761.8	272.0	740.2	287.5	717.6	303.9	698.3	324.2
		8	819.4	245.9	797.8	259.2	782.9	274.9	762.3	290.7	740.1	307.5	719.9	327.5
		10	875.1	260.0	857.7	271.2	837.6	282.4	816.4	298.6	794.2	316.2	773.3	336.0
		12	921.6	265.6	906.1	277.2	884.5	288.8	862.9	305.3	841.7	321.7		
3400 Z 	Glycol water	-8	498.6	225.1	485.3	240.1	468.0	250.0	445.7	263.4	427.0	289.0		
		-6	534.7	229.8	523.1	242.6	504.0	255.4	484.9	269.5	462.6	293.5		
		-4	576.3	234.5	561.4	247.4	543.3	260.9	522.7	275.0	504.0	290.4		
		-2	645.3	242.3	625.3	255.4	612.5	270.6	586.6	284.5	564.9	300.0	542.0	314.2
		0	687.6	247.2	671.1	261.2	651.4	275.8	630.6	291.0	611.8	306.0	583.8	320.3
		2	735.0	252.7	724.9	268.2	698.4	282.4	672.9	303.8	661.4	313.5	632.6	327.6
	Pure water	5	833.8	263.8	814.0	279.9	793.9	295.9	776.0	313.5	746.1	330.0	725.1	342.5
		6	858.7	267.8	838.7	283.3	814.1	305.8	795.8	316.7	773.5	334.6	748.2	350.0
		7	884.0	271.1	865.0	286.9	844.0	311.7	819.9	320.5	793.9	338.2	770.3	356.5
		8	907.2	276.4	890.2	290.3	868.2	315.4	844.5	324.4	819.1	342.6	800.3	363.4
		10	971.7	285.0	948.3	308.3	929.8	324.1	903.9	333.7	877.8	352.8	856.2	373.5
		12	1026.3	295.7	1000.5	314.6	981.0	333.5	952.7	343.3	928.3	361.4		
3750 Z 	Glycol water	-8	557.8	245.0	544.0	260.0	518.0	272.1	493.9	286.8	475.0	307.0		
		-6	593.8	250.9	580.1	265.8	555.3	278.1	536.7	293.6	515.0	311.0		
		-4	641.4	256.7	624.1	270.8	601.5	284.9	577.5	300.0	553.6	316.1		
		-2	715.8	265.6	696.1	280.3	675.6	295.7	648.5	317.3	623.4	335.6	594	351.6
		0	764.4	271.4	743.9	286.5	724.5	302.8	697.9	325.8	672.6	344.1	643.0	359.8
		2	815.3	277.6	801.9	294.4	773.4	310.0	750.3	335.2	717.6	352.7	693.1	361.9
	Pure water	5	921.5	291.0	898.0	313.2	874.0	333.8	844.5	352.9	828.1	370.2	788.8	378.9
		6	948.3	294.4	924.4	319.5	904.6	338.8	872.3	356.6	850.1	374.2	816.8	383.9
		7	976.3	298.0	955.3	323.5	929.5	343.0	902.6	362.2	878.4	379.0	842.8	387.2
		8	1005.4	301.9	981.4	328.7	949.8	347.1	929.8	367.0	900.5	383.4	870.5	391.0
		10	1069.0	320.2	1045.5	338.6	1019.6	358.2	995.8	377.6	967.0	392.0	943.7	402.5
		12	1132.1	330.8	1102.6	347.4	1077.3	367.3	1047.8	388.0	1020.5	411.1		
4200 Z 	Glycol water	-8	665	280	648	297	617	310	589	327	566	350		
		-6	708	286	691	303	661	317	640	335	614	355		
		-4	764	293	744	309	717	325	689	342	660	361		
		-2	853	303	829	319	806	338	773	362	742	383	708	402
		0	910	309	887	327	864	346	832	372	802	392	766	411
		2	971	317	956	335	921	354	894	382	856	403	826	413
	Pure water	5	1099	332	1070	357	1041	381	1006	403	987	422	940	432
		6	1130	335	1101	365	1078	387	1039	407	1013	427	974	438
		7	1163	340	1138	370	1108	391	1076	413	1046	432	1005	442
		8	1198	345	1169	375	1132	396	1108	419	1074	437	1038	446
		10	1274	365	1246	387	1215	408	1187	431	1152	447	1125	460
		12	1349	378	1314	396	1283	419	1249	443	1217	469		

Pf : Cooling capacity calculated with :
 - water inlet/outlet differential as per curves page 16
 - 0.00005 m² °C/W fouling factor
 Pa : Compressors + fans absorbed power

Glycol water is necessary
 Low temperature option necessary
 EUROVENT conditions

DESUPERHEATER EXCHANGER LX - LXH - LXC

The system consists in free hot water supplying thanks to heat recovery on the compressors discharge gas, through an auxiliary desuperheater exchanger.

This optional equipment is only available on request, and factory mounted.

■ Diagram of the refrigerant circuit

The following refrigeration diagram describes an example of a CIAT unit, with desuperheater (on each refrigerant circuit). The heat recovery is possible only if the machine is running.

For the same cooling or heating capacity, the desuperheater system allows a free heating of hot water with a reduction of the total input power of the machine.

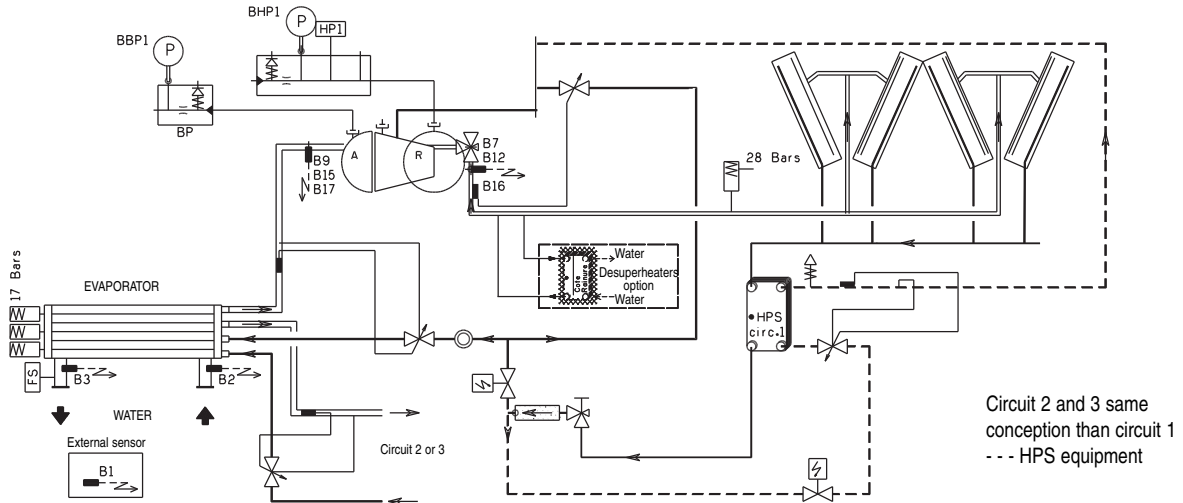

■ Principle and precautions of hydraulic connection

To start and run the machine under good conditions, the circuit must be as short as possible, and the water flow of the desuperheater must start slowly to normal operating condition, with a water flow equal to 10% of its standard value, and must be calculated for a hot water inlet temperature of **+50°C**.

Thus, it is recommended to have a hydraulic diagram making it possible to obtain very quickly a hot water at the inlet of the desuperheater (3-way valve + controller + temperature sensor on the exchanger water inlet)

The controller set point must be adjusted to **+50°C** minimum.

Note: pay attention to the selection of the expansion tank, because the recovery water circuit can reach the temperature of 115°C in the event of circulator stop or non hot water consumption.

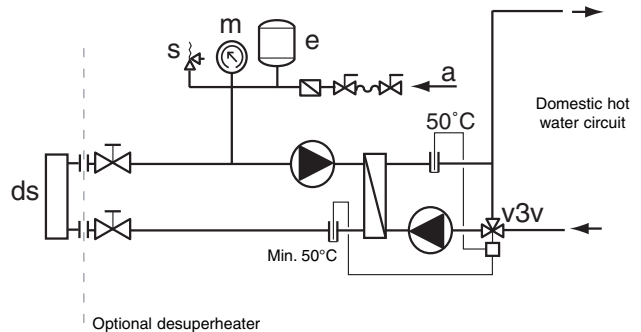

■ Recovery example on desuperheater

POWERCAT LX - LXH - LXC	Cooling capacity Pf (kW)	Absorbed power Pa (kW)	Recovery Pr (kW)	Water flow qv (m³/h)	Pressure drop dP (mCE)
1200Z	236	101	59	10.1	0.31
1200Z HPS	261	110	65	11.2	0.39
1500Z	305	129	76	13.1	0.53
1500Z HPS	338	140	85	14.6	0.66
1850Z	362	156	90	15.5	0.74
1850Z HPS	409	172	102	17.5	0.95
2150Z	429	184	107	18.4	0.68
2150Z HPS	486	202	122	21.0	0.88
2500Z	522	216	131	22.5	1.01
2500Z HPS	594	238	148	25.5	1.30
2800Z	605	244	151	26.0	1.35
2800Z HPS	590	268	173	29.8	1.78
3050Z HPS	740	287	185	31.8	0.90
3400Z HPS	820	320	205	35.3	1.11
3750Z HPS	903	362	226	38.9	1.35
4200Z HPS	1076	413	269	46.3	1.91

Note : heat recovery performances for :

- machine running in full load, chilled water = +12/+7°C and outside air = +35°C°C
- hot water temperature on recovery = +55/+60°C



Air cooled chillers

POWERCAT LX R407C

PARTIAL HEAT RECOVERY CAPACITY

LX LXC LXH	Desuperheater water inlet and outlet temperature in °C	Evaporator water outlet temp. °C	TEMPÉRATURE D'ENTREE D'AIR AU CONDENSEUR °C																							
			26				29				32				35				38				41			
			Pf kW	Pa kW	Pde kW	Qde m³/h	Pf kW	Pa kW	Pde kW	Qde m³/h	Pf kW	Pa kW	Pde kW	Qde m³/h	Pf kW	Pa kW	Pde kW	Qde m³/h	Pf kW	Pa kW	Pde kW	Qde m³/h	Pf kW	Pa kW	Pde kW	Qde m³/h
3050 Z	50 °C / 55 °C	5	753	238	113	19	733	251	147	25	718	266	180	31	695	281	209	36	680	298	238	41	644	317	258	44
		6	771	240	116	20	758	253	152	26	739	269	185	32	719	285	216	37	699	301	245	42	678	321	271	47
		7	796	243	119	21	778	256	156	27	761	272	190	33	740	288	222	38	717	304	251	43	698	324	279	48
		8	819	246	123	21	797	259	159	27	782	275	196	34	762	291	229	39	740	308	259	45	720	328	288	50
		10	875	260	131	23	857	271	171	29	837	282	209	36	816	299	245	42	794	316	278	48	773	336	309	53
		12	921	266	138	24	906	277	181	31	884	289	221	38	862	305	259	44	841	322	294	51				
	55 °C / 60 °C	5	753	238	75	13	733	251	110	19	718	266	144	25	695	281	174	30	680	298	204	35	644	317	225	39
		6	771	240	77	13	758	253	114	20	739	269	148	25	719	285	180	31	699	301	210	36	678	321	237	41
		7	796	243	80	14	778	256	117	20	761	272	152	26	740	288	185	32	717	304	215	37	698	324	244	42
		8	819	246	82	14	797	259	120	21	782	275	156	27	762	291	191	33	740	308	222	38	720	328	252	43
		10	875	260	88	15	857	271	129	22	837	282	167	29	816	299	204	35	794	316	238	41	773	336	271	47
		12	921	266	92	16	906	277	136	23	884	289	177	30	862	305	216	37	841	322	252	43				
3400 Z	50 °C / 55 °C	5	833	264	125	21	814	280	163	28	793	296	198	34	776	314	233	40	746	330	261	45	725	343	290	50
		6	858	268	129	22	838	283	168	29	814	306	204	35	795	317	239	41	773	335	271	47	748	350	299	51
		7	884	271	133	23	865	287	173	30	844	312	211	36	819	321	246	42	793	338	278	48	770	357	308	53
		8	907	276	136	23	890	290	178	31	868	315	217	37	844	324	253	44	819	343	287	49	800	363	320	55
		10	971	285	146	25	948	308	190	33	929	324	232	40	903	334	271	47	877	353	307	53	856	374	342	59
		12	1026	296	154	26	1000	315	200	34	981	334	245	42	952	343	286	49	928	361	325	56				
	55 °C / 60 °C	5	833	264	83	14	814	280	122	21	793	296	159	27	776	314	194	33	746	330	224	38	725	343	254	44
		6	858	268	86	15	838	283	126	22	814	306	163	28	795	317	199	34	773	335	232	40	748	350	262	45
		7	884	271	88	15	865	287	130	22	844	312	169	29	819	321	205	35	793	338	238	41	770	357	270	46
		8	907	276	91	16	890	290	134	23	868	315	174	30	844	324	211	36	819	343	246	42	800	363	280	48
		10	971	285	97	17	948	308	142	24	929	324	186	32	903	334	226	39	877	353	263	45	856	374	300	52
		12	1026	296	103	18	1000	315	150	26	981	334	196	34	952	343	238	41	928	361	278	48				
3750 Z	50 °C / 55 °C	5	921	291	138	24	898	313	180	31	874	334	219	38	844	353	253	44	828	370	290	50	789	379	316	54
		6	948	294	142	24	929	320	186	32	904	339	226	39	872	357	262	45	850	374	298	51	817	384	327	56
		7	976	298	146	25	955	324	191	33	929	343	232	40	902	362	271	47	878	379	307	53	843	387	337	58
		8	1005	302	151	26	981	329	196	34	949	347	237	41	929	367	279	48	900	383	315	54	870	391	348	60
		10	1069	320	160	28	1045	339	209	36	1019	358	255	44	995	378	299	51	967	392	338	58	943	403	377	65
		12	1132	331	170	29	1102	347	220	38	1077	367	269	46	1047	388	314	54	1020	411	357	61				
	55 °C / 60 °C	5	921	291	92	16	898	313	135	23	874	334	175	30	844	353	211	36	828	370	248	43	789	379	276	47
		6	948	294	95	16	929	320	139	24	904	339	181	31	872	357	218	37	850	374	255	44	817	384	286	49
		7	976	298	98	17	955	324	143	25	929	343	186	32	902	362	226	39	878	379	263	45	843	387	295	51
		8	1005	302	101	17	981	329	147	25	949	347	190	33	929	367	232	40	900	383	270	46	870	391	305	52
		10	1069	320	107	18	1045	339	157	27	1019	358	204	35	995	378	249	43	967	392	290	50	943	403	330	57
		12	1132	331	113	19	1102	347	165	28	1077	367	215	37	1047	388	262	45	1020	411	306	53				
4200 Z	50 °C / 55 °C	5	1099	332	165	28	1070	357	214	37	1041	381	260	45	1006	403	302	52	987	422	316	54	940	432	376	65
		6	1130	335	170	29	1101	365	220	38	1078	387	270	46	1039	407	312	54	1013	427	324	56	974	438	390	67
		7	1163	340	174	30	1138	370	228	39	1108	391	277	48	1076	413	323	56	1046	432	335	58	1005	442	402	69
		8	1198	345	180	31	1169	375	234	40	1132	396	283	49	1108	419	332	57	1074	437	344	59	1038	446	415	71
		10	1274	365	191	33	1246	387	249	43	1215	408	304	52	1187	431	356	61	1152	447	369	63	1125	460	450	77
		12	1349	378	202	35	1314	396	263	45	1283	419	321	55	1249	443	375	64	1217	469	389	67				
	55 °C / 60 °C	5	1099	332	110	19	1070	357	161	28	1041	381	208	36	1006	403	252	43	987	422	296	51	940	432	329	57
		6	1130	335	113	19	1101	365	165	28	1078	387	216	37	1039	407	260	45	1013	427	304	52	974	438	341	59
		7	1163	340	116	20	1138	370	171	29	1108	391	222	38	1076	413	269	46	1046	432	314	54	1005	442	352	61
		8	1198	345	120	21	1169	375	175	30	1132	396	226	39	1108	419	277	48	1074	437	322	55	1038	446	363	62
		10	1274	365	127	22	1246	387	187	32	1215	408	243	42	1187	431	297	51	1152	447	346	59	1125	460	394	68
		12	1349	378	135	23	1314	396	197	34	1283	419	257	44	1249	443	312	54	1217	469	365	63				

Pf : Cooling capacity valid a DT according to operating limitst
 Pa : Compressors + fans absorbed power
 Pde: Desuperheater heating capacity recovered
 Qde : Desuperheater water flow



DIMENSIONS LX - LXH

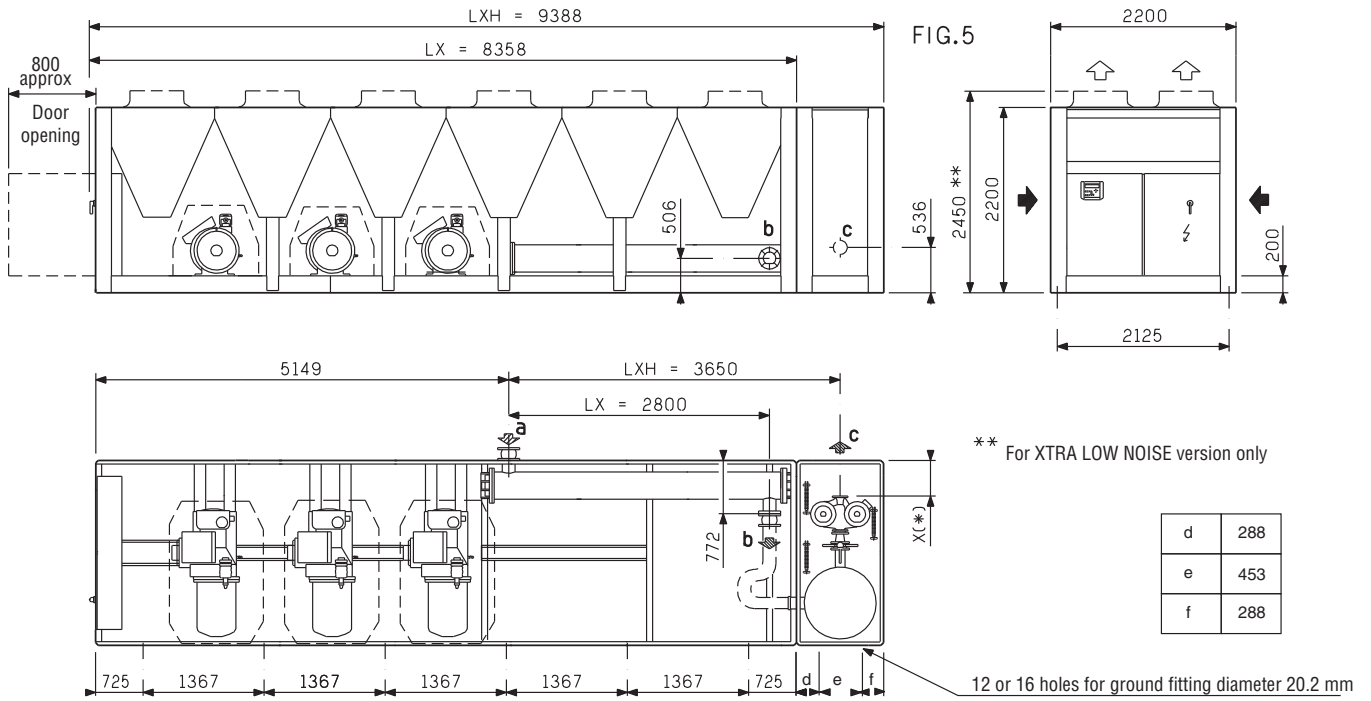

Models	Fig.	Chilled water			Weight kg	
		inlet LX / LXH a	outlet LX b	outlet LXH c	empty	in operation
LX 3050Z HPS	5	VICTAULIC DN 200	DN 200	*	6940	7186
LXH 3050Z HPS					7690	8986
LX 3400Z HPS	5	VICTAULIC DN 200	DN 200	*	7383	7629
LXH 3400Z HPS					8133	9429
LX 3750Z HPS	5	VICTAULIC DN 200	DN 200	*	7826	8072
LXH 3750Z HPS					8576	9872

* c according to the selected pump (see p.26)



ANTI-VIBRATION MOUNTS (OPTION)

POWERCIAT LXH

For applications with very low vibrations, it is necessary to install anti-vibration mounts underneath the unit.

The fitting of mounts must be made according to the drawings below

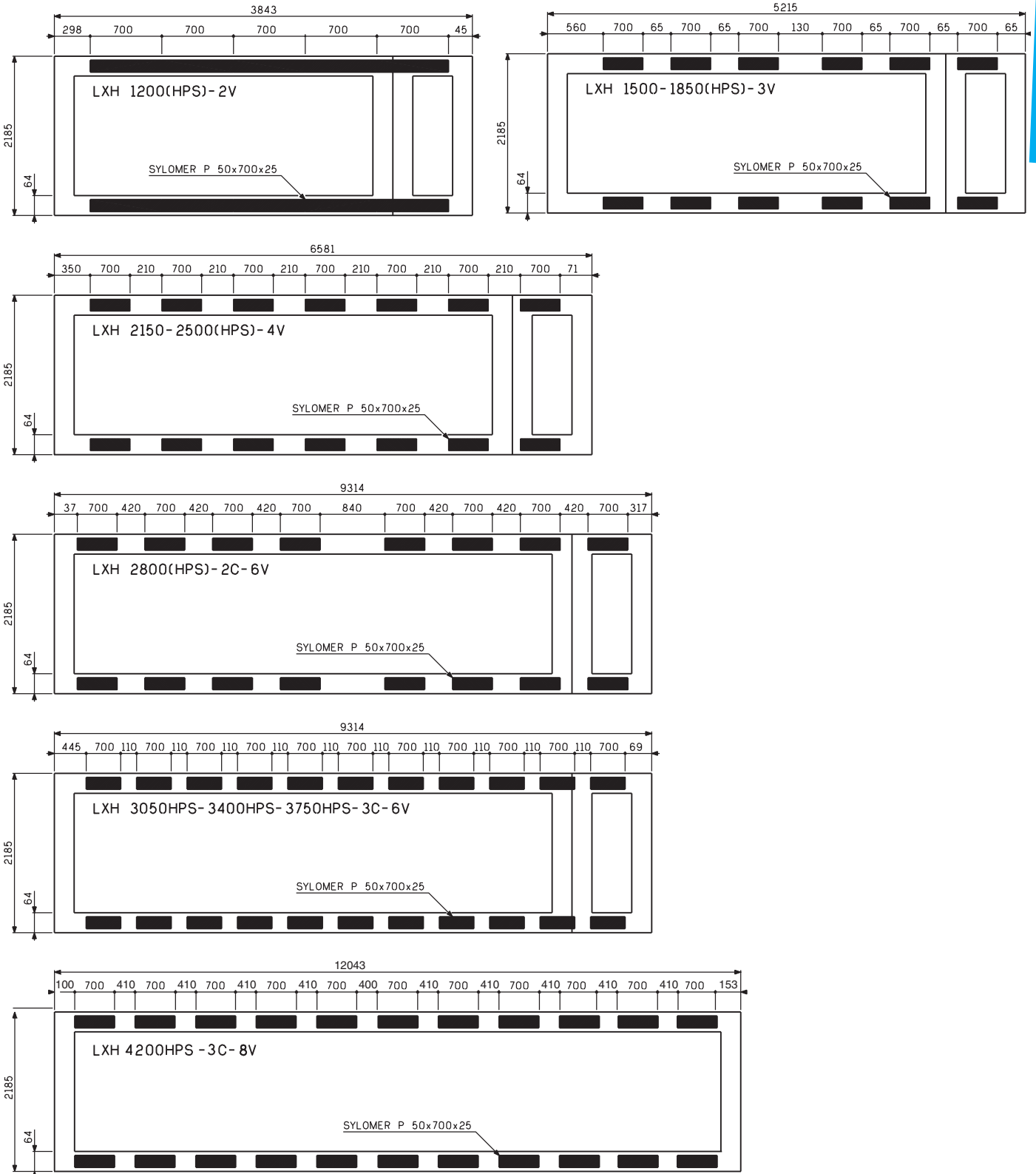



XTRACONNECT CONTROL



ERGONOMIC INTERFACE PANEL

- LDC multilingual screen (2 lines of 20 characters)
- Pressures and temperatures reading
- Pump control
- Communication

Available free contacts inputs / outputs

- Inputs :**
- External ON/OFF contact
 - Chilled water pump external ON/OFF contact
 - Setpoint 1/2 selection
 - General fault
 - Emergency stop
 - Compressors load shedding
 - 0 - 20 mA remote control
- Output :**
- General fault of the unit
 - General fault per circuit
 - Pump control

RS 485 OUTPUT IN STANDARD

- MODBUS-JBUS open Protocol (standard)**
- LONWORKS Protocol (option)**

FREE CONTACTS RELAY CARD (OPTION)

Available outputs :

- Water flow fault
- Antifreeze fault
- Pump fault
- Fans fault
- Emergency stop fault
- Low and high pressure fault
- Compressors safety fault
- Compressors superheating fault
- Compressors lubrication fault
- Discharge temperature fault
- Compressors running

REMOTE CONTROL BOX (OPTION)

- Operation and design same as display console**

MULTICONNECT MULTI-UNIT MANAGEMENT (OPTION)

Main functions available:

- Management of up to 8 units on a single water loop
- Management in cooling mode (water chiller) or heating mode (heat pump)
- Management of chilled-water or hot-water pumps
- Centralised management of a backup unit
- Unit load shedding
- System time programming
- Energy storage mode management
- Fault management on each unit
- Unit running time balancing
- Integrated Modbus BMS link for obtaining information on unit operation and faults

Non contractual document. With the thought of material improvement always in mind, CIAT reserves the right, without notice, to proceed with any technical modification.

Head office & Factories

Avenue Jean Falconnier - B.P. 14
01350 - Culoz - France
Tel.: 33 4 79 42 42 42 - Fax: 33 4 79 42 42 10
e-mail: info@ciat.fr - http://www.ciat.com



CIAT Service
Tél. : 33 4 79 42 42 90 - Fax : 33 4 79 42 42 13

CERTIFIED ISO 9001
QUALITY SYSTEM



Compagnie Industrielle d'Applications Thermiques - S.A. with a registered capital of 26 000 000 € - R.C.S. Belley B 545 620 114